

SPECIFICATION:

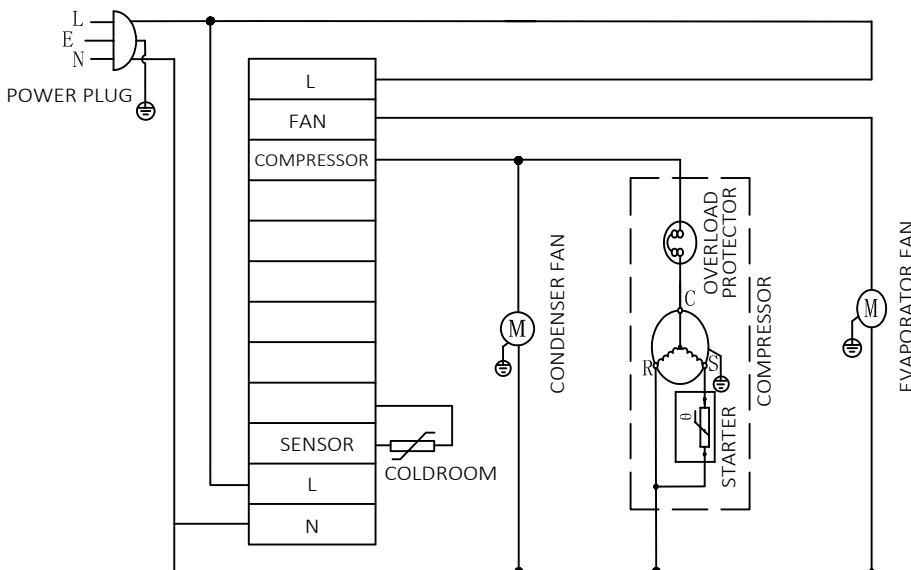

MODEL	CDD-24
Exterior Dimensions W*D*H	596*767*1011
Interior Dimensions W*D*H	496*460*726
Packing Dimensions W*D*H	660*820*1140
Net Volume cu ft	220L
Temperature Range (F)	33~40
Compressor Power (HP)	1/6
Refrigerant	R290
Isolation Material	Polyurethane
Cooling System	Ventilated
Net Weight lbs	165kg
Shipping Weight lbs	185kg
Door	1
Shelves	0
Housing Material	Painted steel
Liner Material	SS201
Shelf Material	Plastic Coated Steel
Type of Controller	Digital
Climate Rating (F)	90
Connection Rating Amp/Watts	1.92A/216W
Voltage/Frequency	115V/60HZ

CIRCUIT DIAGRAM:



CONFORMS TO UL STD.471 CERTIFIED TO CSA
STD.C22.2No. 120 CONFORMS TO NSF/ANSI
STD. 18 CONFORMS TO NSF/ANSI STD. 7

TECHNIC PARAMETER	
DESIGNED PRESSURE	
HIGH SIDE	320PSI
LOW SIDE	180PSI
REFRIGERANT	R290
AMOUNT	2.11oz
FOAM AGENT	C-PENTANE
RATED VOLTAGE	AC115V
FREQUENCY RATED	60Hz
CURRENT	1.92A
POWER INPUT	216W
NET WEIGHT	60Kg
MANUFACTURED	

Specifications subject to change without notice.

PARTS:

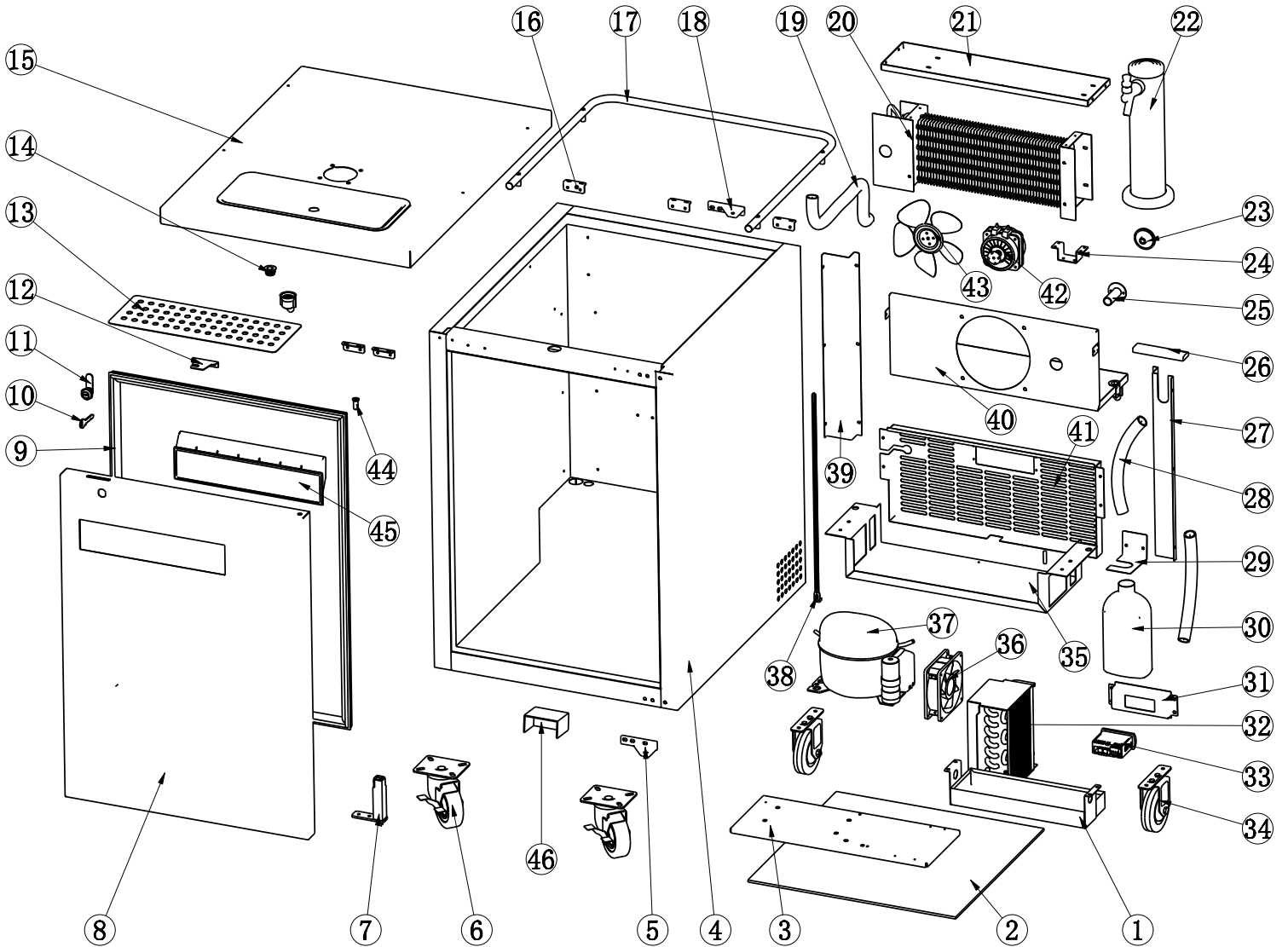

No	Part English Name	QTY
1	OUTER DRAIN PAN	1
2	RUBBER PAD	1
3	COMPRESSOR INSTALLATION BOARD	1
4	CABINET	1
5	BOTTOM RIGHT HINGE	1
6	CASTER WITH BREAK	2
7	HINGE AXIS	1
8	DOOR	1
9	GASKET	1
10	KEY	1
11	LOCK	1
12	LOCK PLATE	1
13	COVER FOR BEER DRIP PAN	1
14	DRAIN CONNECTOR FOR BEER DRIP PAN	2
15	TOP BOARD	1
16	TOP BOARD FIXER	4

No	Part English Name	QTY
17	STAINLESS STEEL GUARD RAIL	1
18	UPPER RIGHT HINGE	1
19	CORRUGATED PIPE	1
20	EVAPORATOR	1
21	FAN MOTOR INSTALLATION PANEL	1
22	BEER TOWER KIT - ONE TAP	2
23	RUBBER TUBE PLUG	1
24	EVAPORATOR FAN HOLDER	1
25	RUBBER TUBE COVER	1
26	THERMOMETER	1
27	DRAIN HOSE COVER BOARD	1
28	DRAIN HOSE	2
29	FIXER FOR PLASTCI BOTTLE	1
30	PLASTIC BOTTLE FOR DRIPPED BEER	1
31	THERMOSTAT INSTALLATION COVER	1

No	Part English Name	QTY
32	CONDENSER	1
33	THERMOSTAT	1
34	CASTER WITHOUT BREAK	2
35	BASE BOARD FOR MACHINE ROOM	1
36	CONDENSER FAN MOTOR	1
37	COMPRESSOR	2
38	BELT FOR GAS TANK	1
39	AIR PIPE PROTECTION BOARD	1
40	EVAPORATOR COVER	1
41	BACK GRILL	1
42	EVAPORATOR FAN MOTOR	1
43	EVAPORATOR FAN MOTOR BLADE	1
44	AXIS COVER	2
45	DOOR HANDLE	1
46	WATERPROOF COVER FOR THERMOSTAT	1

Specifications subject to change without notice.

DIMENSIONS:

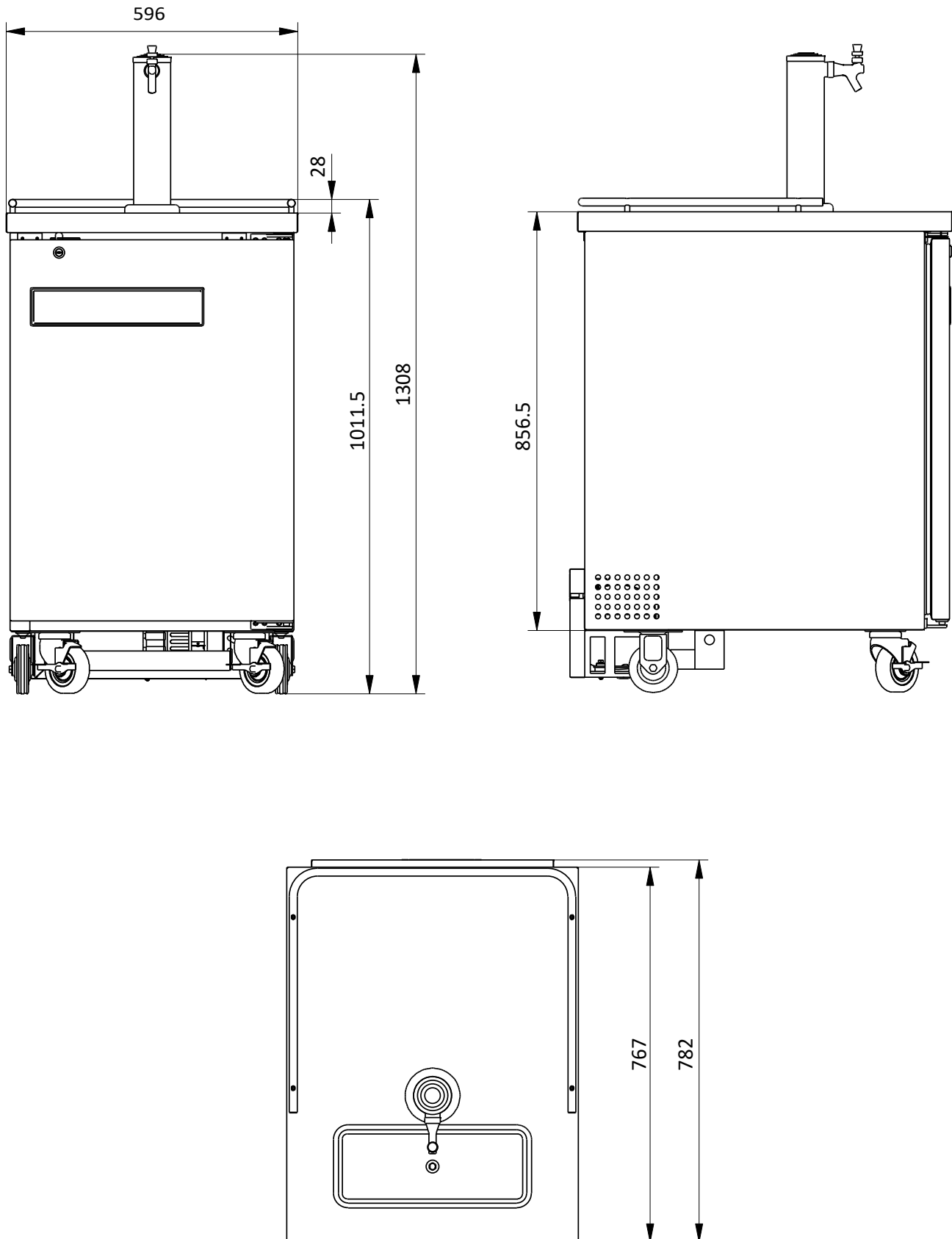

Specifications subject to change without notice.