

Specifications

Part Number	503.00.000.00
Electrical network, V/Hz	115/60
Dedicated Circuit, A	15
Compressor Power, HP	1/6+
Power consumption, Wt	326
Operating amperage, A	4,0
Internal volume, l	214
Net volume, l	188
Refrigerant	R134a or R290
The temperature in the inner volume, °F	28 ÷ 37
Width, in	23,6
Depth, in	30,8
Height, in	38,3
Height of the column, in	56,7
Net Weight, lbs	123.5
Power cord length, ft	7
Operating ambient temperature, °F	50÷90
Clearance	Ask your dealer
Refrigerant (R-134) charge, lb	0,44
Maximum capacity keg container (50 l), pcs	1
Slew rate the product (up to 35.6 °F) at T= 89.6 °F	20h.

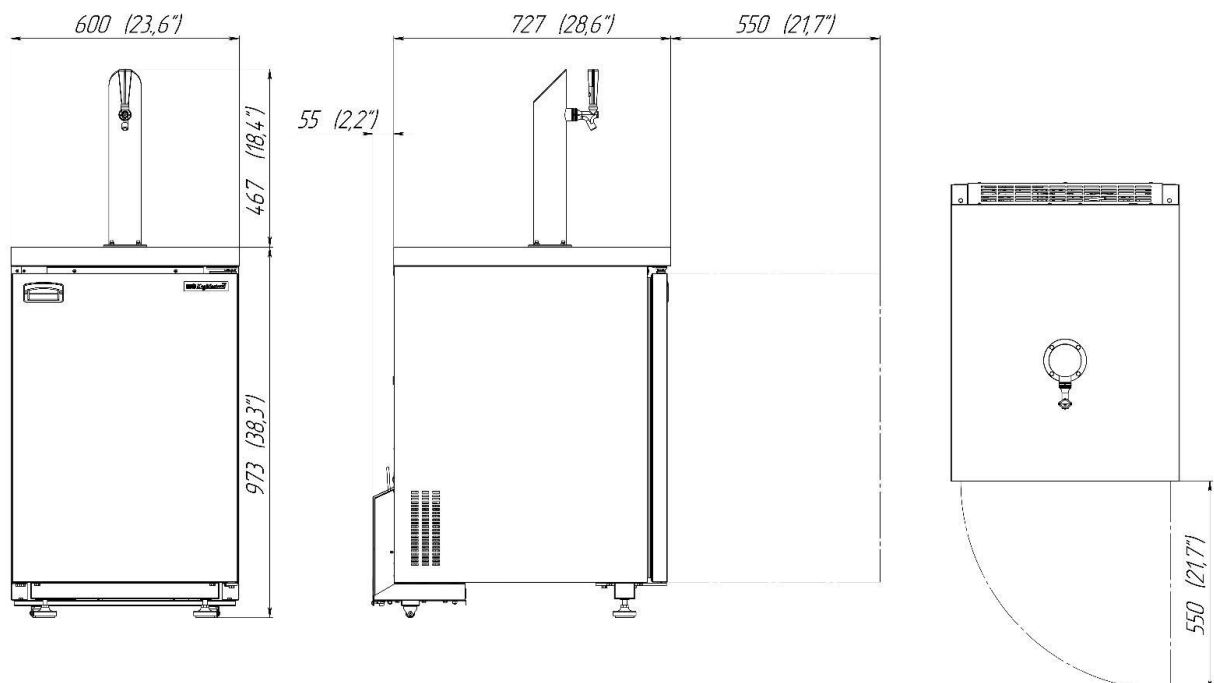

Overall dimensions



Wiring diagram

