

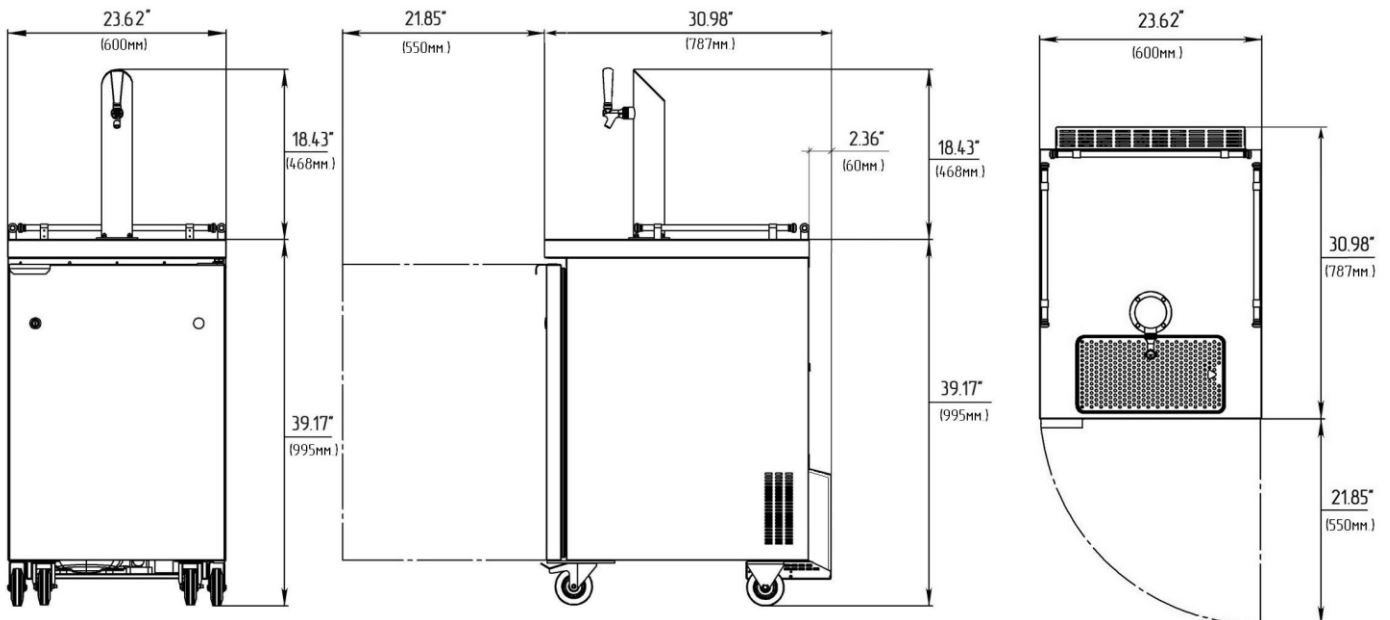

Specifications

Internal Number	500.00.000.00-50
Part Number	KM-1/5NT-P
Compressor Power, HP	1/6
Dedicated Circuit, amp	15
Power consumption, Wt	205
Operating amperage, A	2.5
Internal volume, l	214
Net volume, l	188
Refrigerant	R290 or R134A
The temperature in the inner volume, °F	28 ÷ 37
Width, in	23,62
Depth, in	30,98
Height, in	39,17
Height of the column, in	57,6
Net Weight, lbs	141,1
Power cord length, ft	7
Operating ambient temperature, °F	50÷90
Clearance	Ask your dealer
Refrigerant (R-290) charge, lb	0,187
Maximum capacity keg container (1/2 barrel keg / 50 L), pcs	1
Slew rate the product (up to 35,6 °F) at T= 89,6 °F	10 h.48 min.

Overall dimensions



Wiring diagram

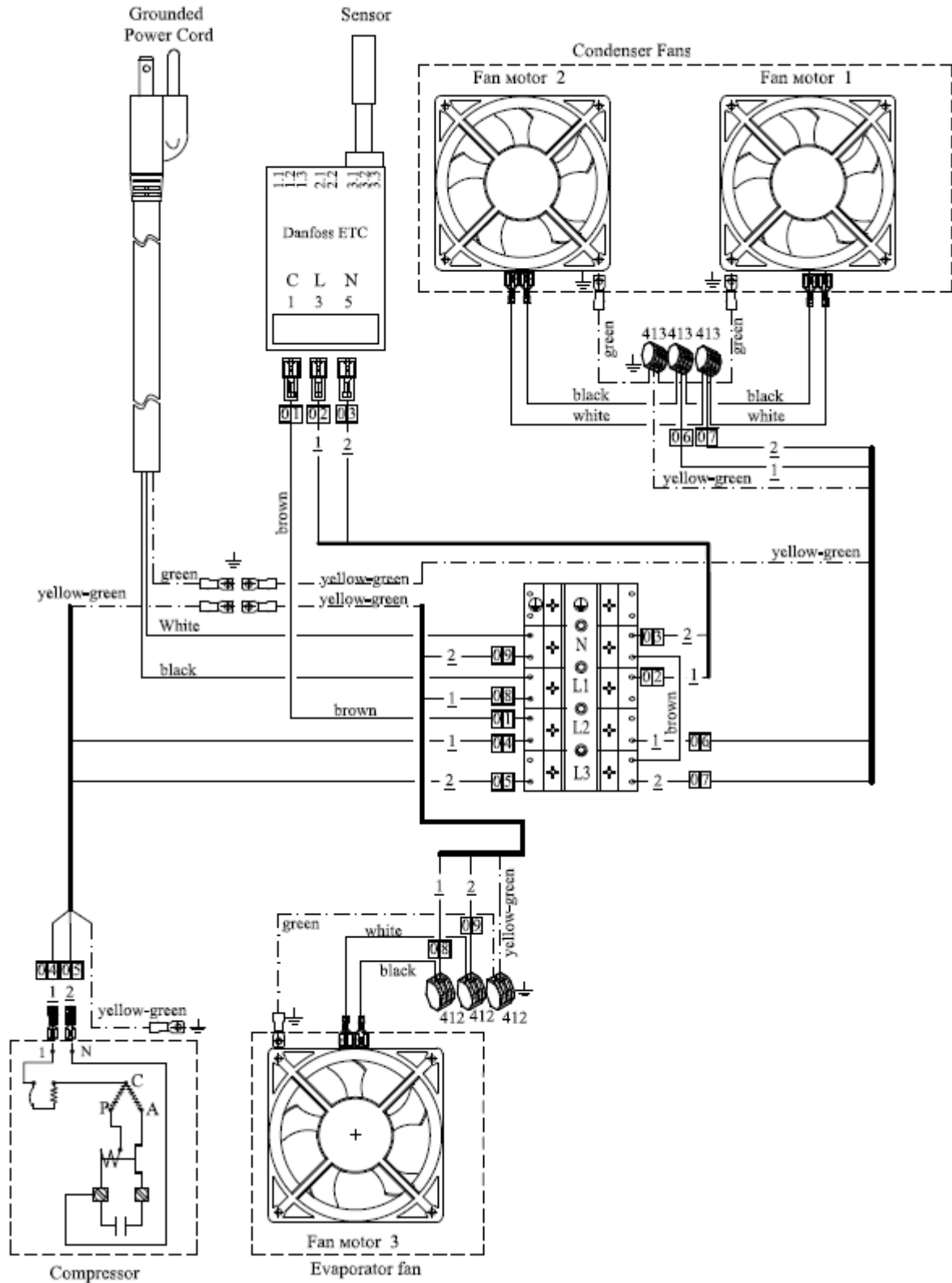

Parts

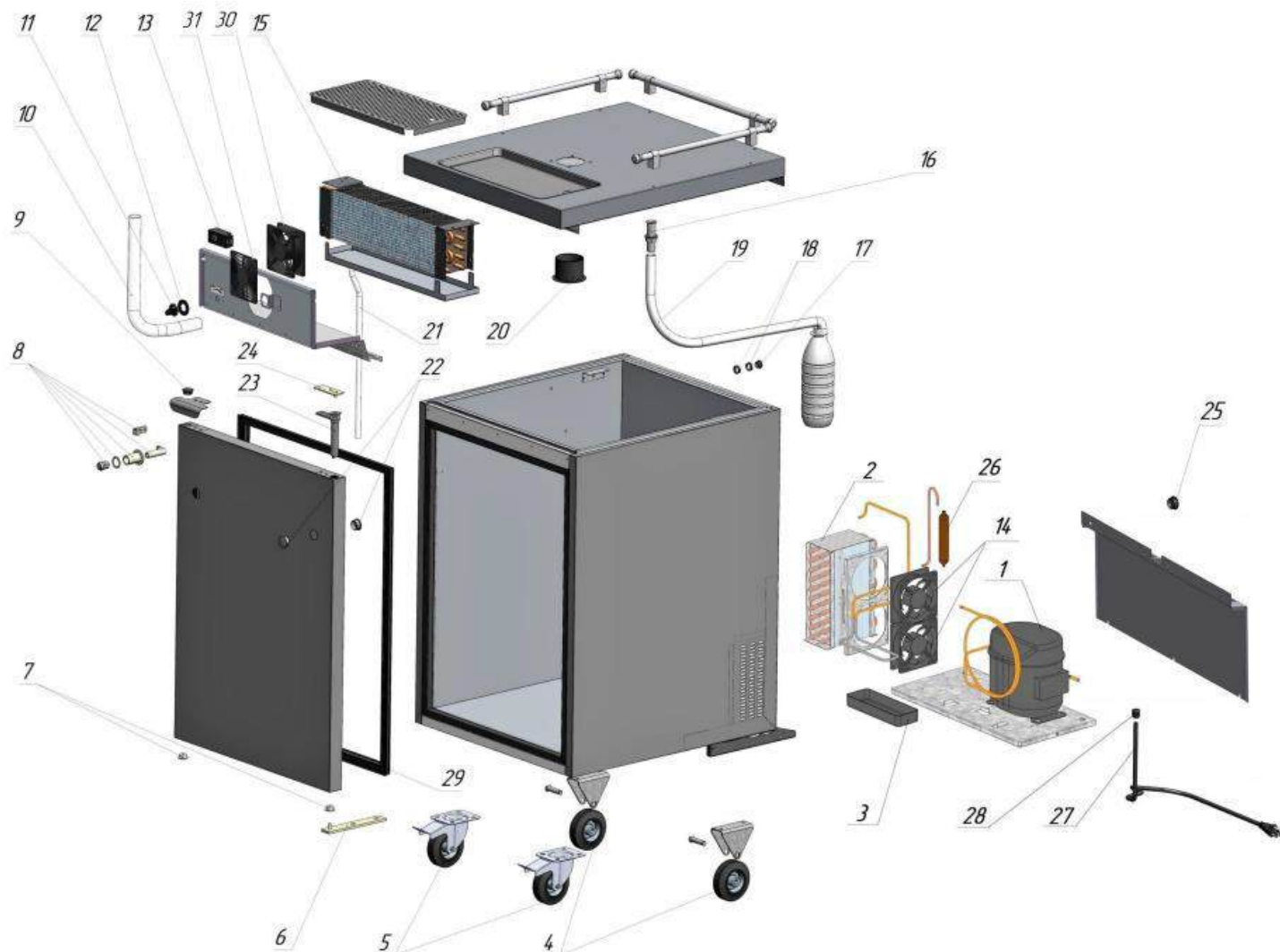

1	Compressor – “Cubigel” NBC30NR	12	Plate for knob termostat - cod. 077B7677	23	Hinge - type CT9097D
2	AIR Condenser - type B-13147	13	Thermostat - type ETC1H1, cod.077F1588	24	Bracket door - cod. 500.03.300.00
3	Drip tray - cod. 500.06.000.10	14	Condenser Fans – type “SUNON” SP100A1123XBT	25	Cap - type 62MP1000
4	Wheels – type PA/PU 80-32-37-300	15	Evaporator - type B-13148	26	Drier filter - type GR-30
5	Wheels - type PA/PU/Sz/R/80-32-37-108-105 x85 (1)-9/80x60-300	16	Drain tube - type 20x75 cod.0001	27	Power cord - SJTOW 16AWG/3 105°
6	Bracket door - type S1401	17	Cap -type 20x75 cod.0001	28	Clamp - type 23MP06N34EZ
7	Nylon bushing - type TO901	18	Protective ring - type 22MP01060	29	Magnetic gasket - cod. 510.03.200.00
8	Lock - type CHF4401	19	Drain hose - PVC , ID=0,71(in). OD=0,87(in)	30	Evaporator fan - type "EBM" 9906
9	Cap -type - POP-875, cod.3083	20	Bushing - cod. 500.02.000.01	31	Grid - type LZ30-5
10	Air conduit - ID=0.984 in. cod. 076470	21	Drain hose - RAUALCO SK-017-029 RAU-PVC 8766 cod. 049203-001		
11	Knob termostat - cod. 077B7662	22	Cap - type POP-1000, cod.3086		